



## Product Information

### CA2-FUNK • *CompactPCI*<sup>®</sup> to PCI Adapter

Document Nr. 2199 • Edition 1 December 2010

*As an industrial standard, CompactPCI<sup>®</sup> is a modular solution for configuring industrial grade PC systems.*

Today's market is offering a broad variety of CPCI I/O solutions. However, in some cases the system integrator needs a special function available on a standard PCI card only.

The CA2-FUNK is a 3U (single size Eurocard) CompactPCI<sup>®</sup> carrier board, with up to three slots for accommodating standard PCI cards.

The CA2-FUNK provides a PCI to PCI bridge, hence being electrically as well as mechanically a perfectly smooth interface between the worlds of PCI and CPCI.

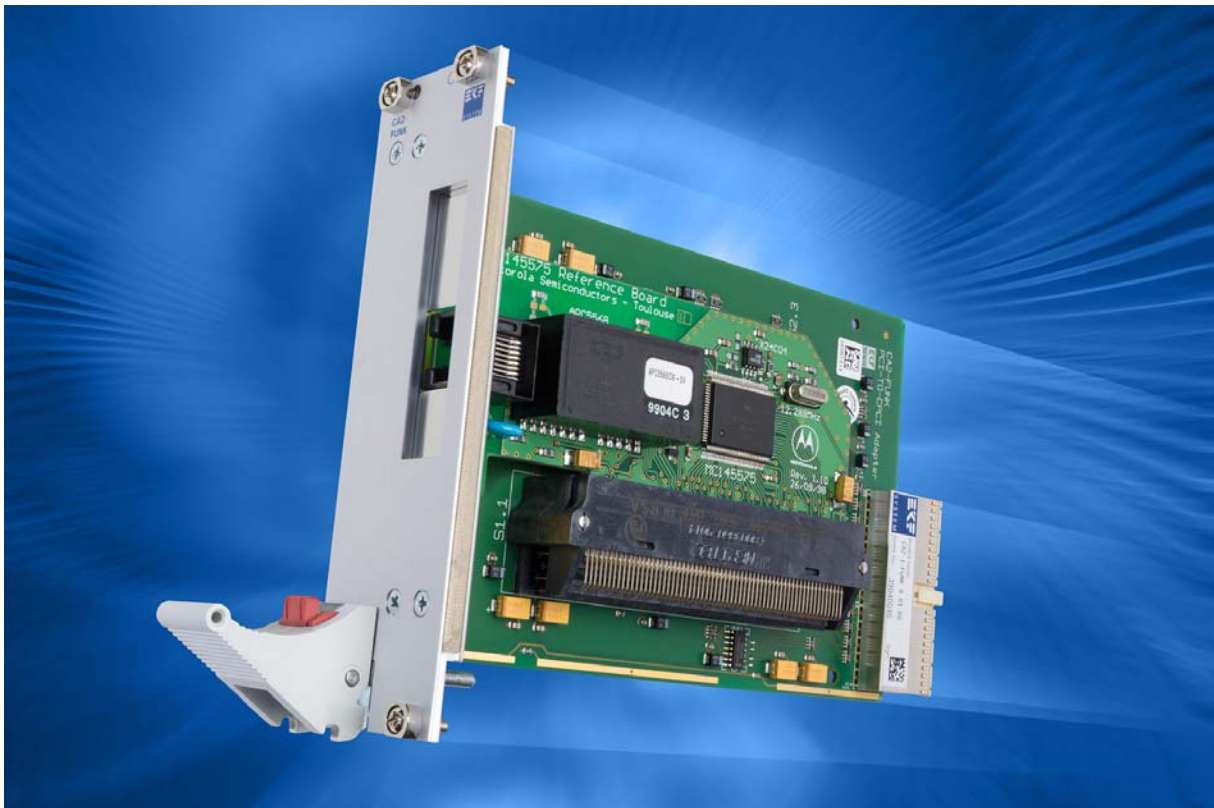

CA2-1 with PCI Card Mounted



CA2-4-FUNK with PCI Card Mounted

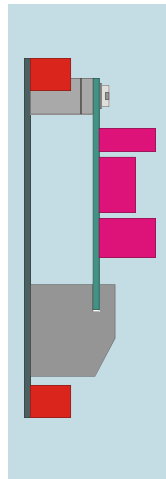

CA2-1

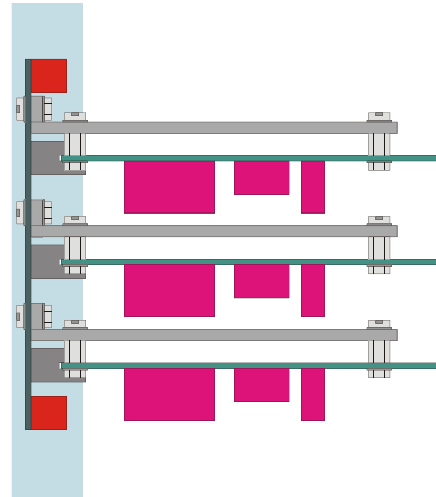

CA2-2

The adapter CA2-FUNK is available in several different versions. The CA2-1 is suitable to carry a single PCI card with dimensions up to  $160 \times 57 \text{mm}^2$ . The PCI card is mounted in parallel to the CA2-1 base board (slot 1b), which is provided with a 8HP (40.6mm) front panel to cover both boards. For new designs, the CA2-4 is recommended as a replacement, which is provided with a 6U front panel.

Choosing the CA2-2, up to three PCI short cards with maximum dimensions of  $160 \times 106.68 \text{mm}^2$  can be mounted in a right angle to the carrier board (slots 1a/2/3). This solution needs up to 24HP rack mounting width, depending on the height of the PCI cards. It is therefore recommended to use the outmost right slot of the systems backplane for the CA2-FUNK whenever possible (this slot must not be the system slot in that case).

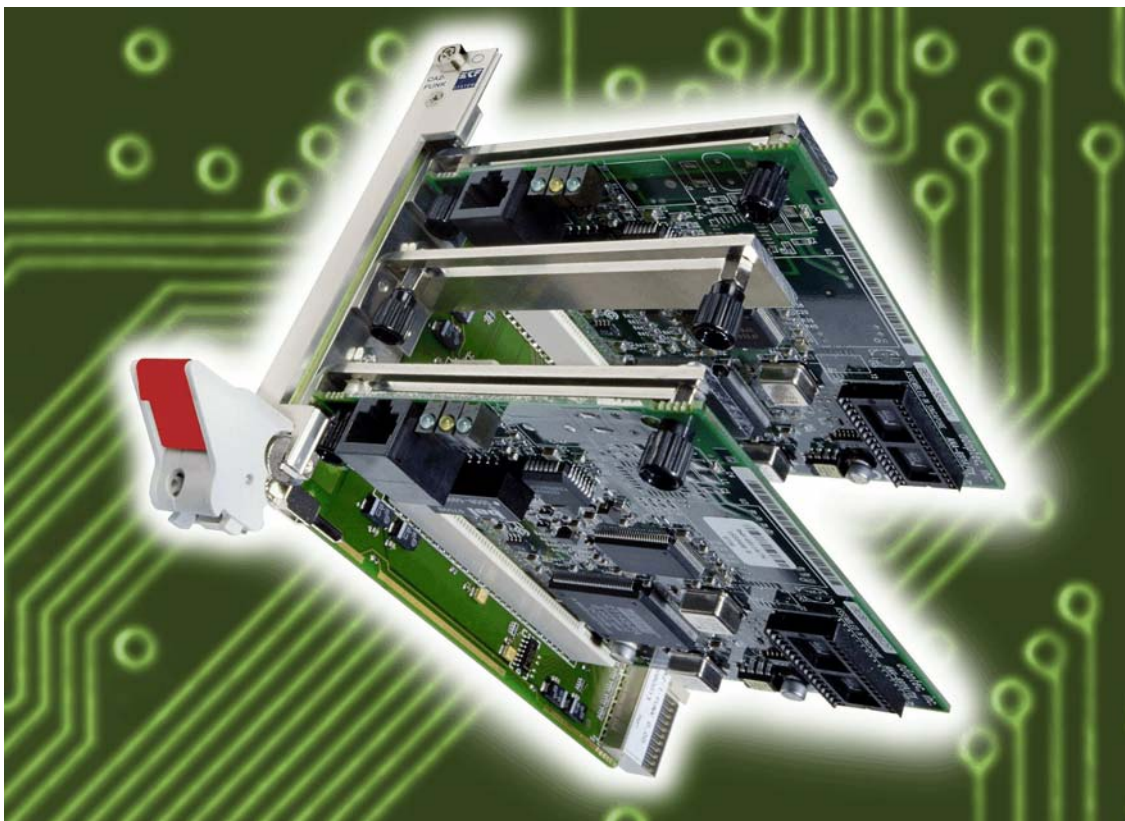

CA2-2 with PCI Boards

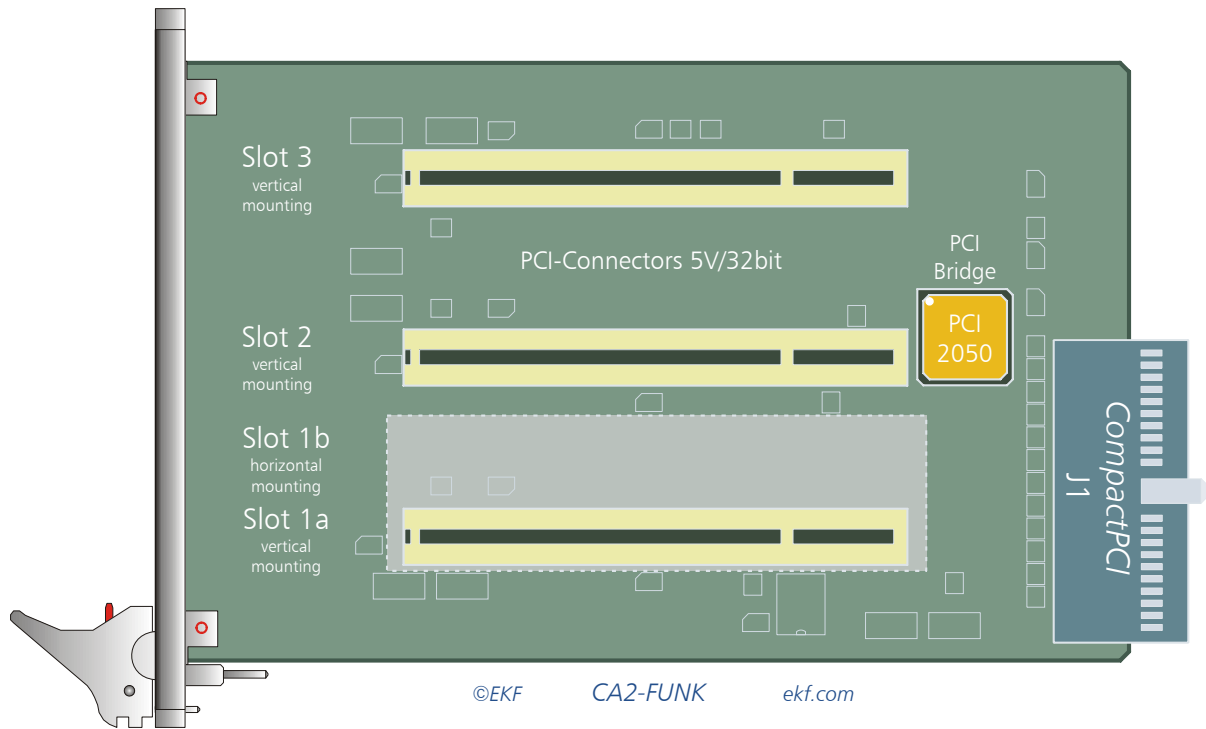

The CA2-3 version is similar to the CA2-2 in respect of the orientation of the add-on PCI boards to be used with it, but provides a 28HP front panel, completely covering and fixing the PCI cards.

Custom specific front panels are available for all CA2 versions. A major goal to be solved was the fastening of the PCI cards on the CA2-FUNK carrier board in a reliable manner, withstanding mechanical shock and vibrations.

*Before being mounted onto the CA2, the metal brackets of the PCI cards would have to be shortened (CA2-1-FUNK) or totally removed (CA2-2-FUNK). This treatment however is not necessary for the CA2-3-FUNK and the CA2-4-FUNK.*

In order to fully comply with both, PCI and CompactPCI® specifications, the CA2-FUNK is provided with a PCI to PCI 32bit bridge chip.

By its built-in buffers, the bridge can speed up system data transfer rates compared to the individual PCI board in use. From the CPCI system controllers view, the CA2-FUNK is a PCI sub-bus with 3 slots.

Some competitors products do not provide a PCI bridge, thus reducing adapter costs (by tolerating a violation of the PCI specs). Overall PCI compatibility however is a must in order to achieve total system reliability. Please bear these facts in mind, when comparing prices to the CA2-FUNK.

*Use of the CA2-FUNK adapter for embedding standard PCI boards into a CompactPCI® system is both a smooth technical solution, and a smart economical decision, whenever time to market counts, or the number of systems to be built is limited, or the function to be implemented underlies fast innovation cycles. Time (to market) is money!*

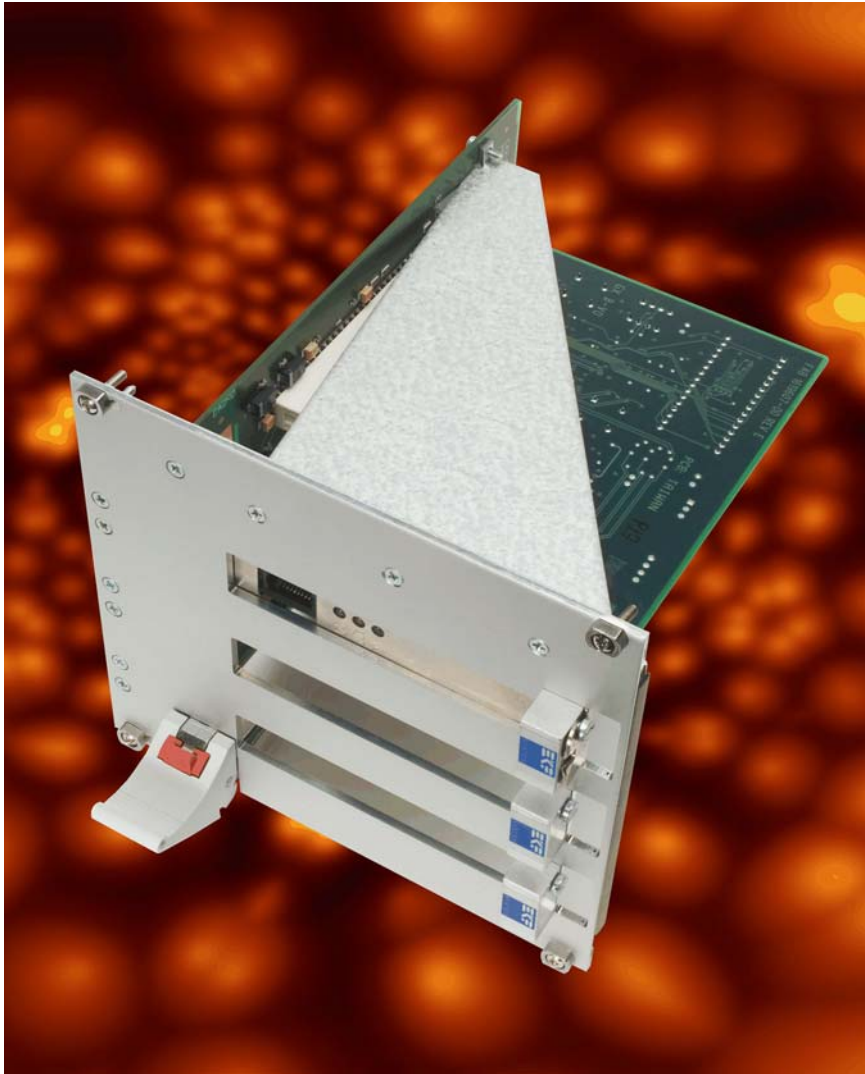

CA2-3 with PCI Board

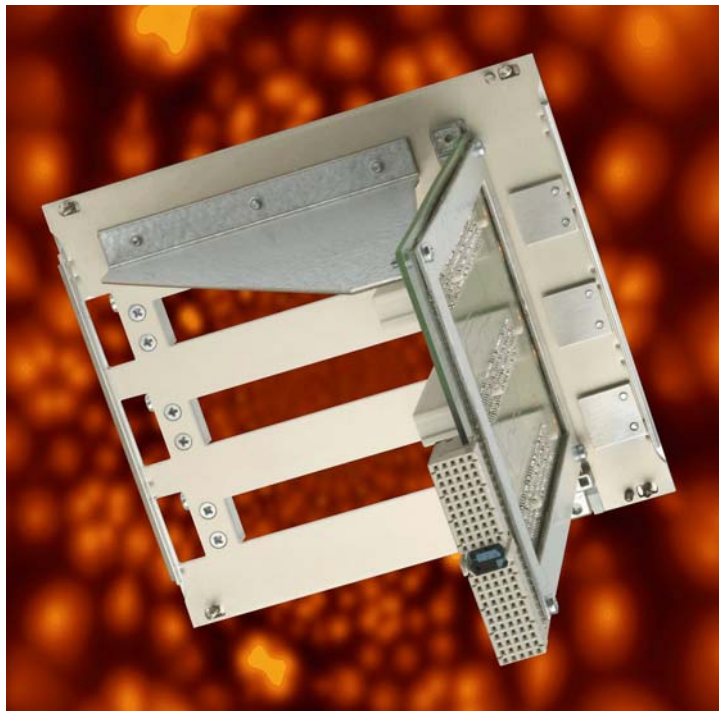

CA2-3 Front Panel Rear View



CA2-1-FUNK Front View, w/o PCI Card



CA2-1-FUNK Front View, with PCI Card



CA2-4-FUNK Front View

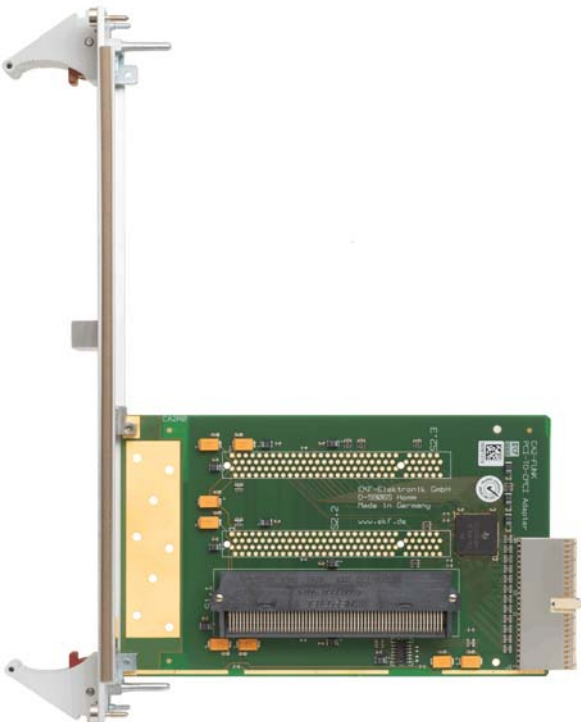

CA2-4-FUNK Top View



CA2-4-FUNK w. PCI Card Top View

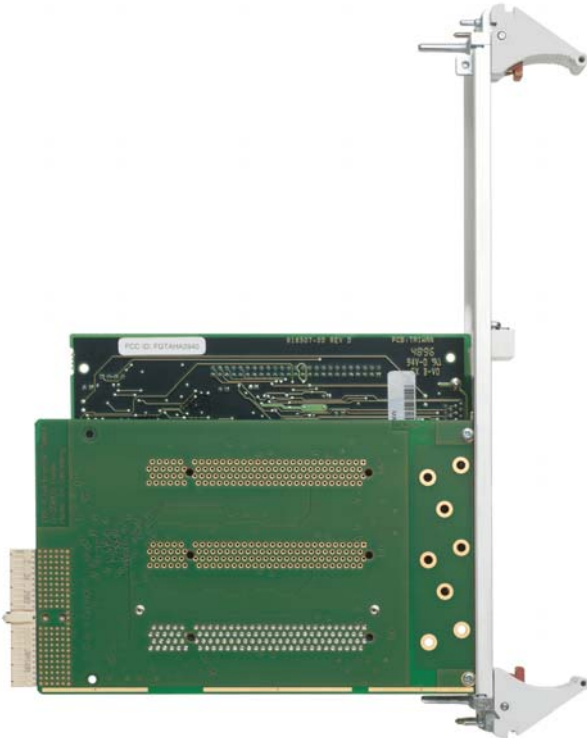

CA2-4-FUNK Bottom View

Block Diagram CA2-FUNK

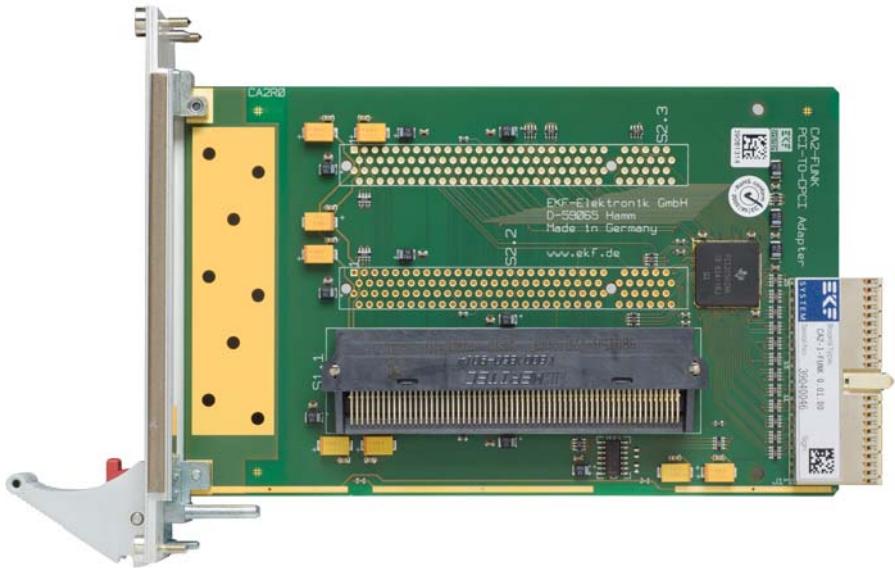
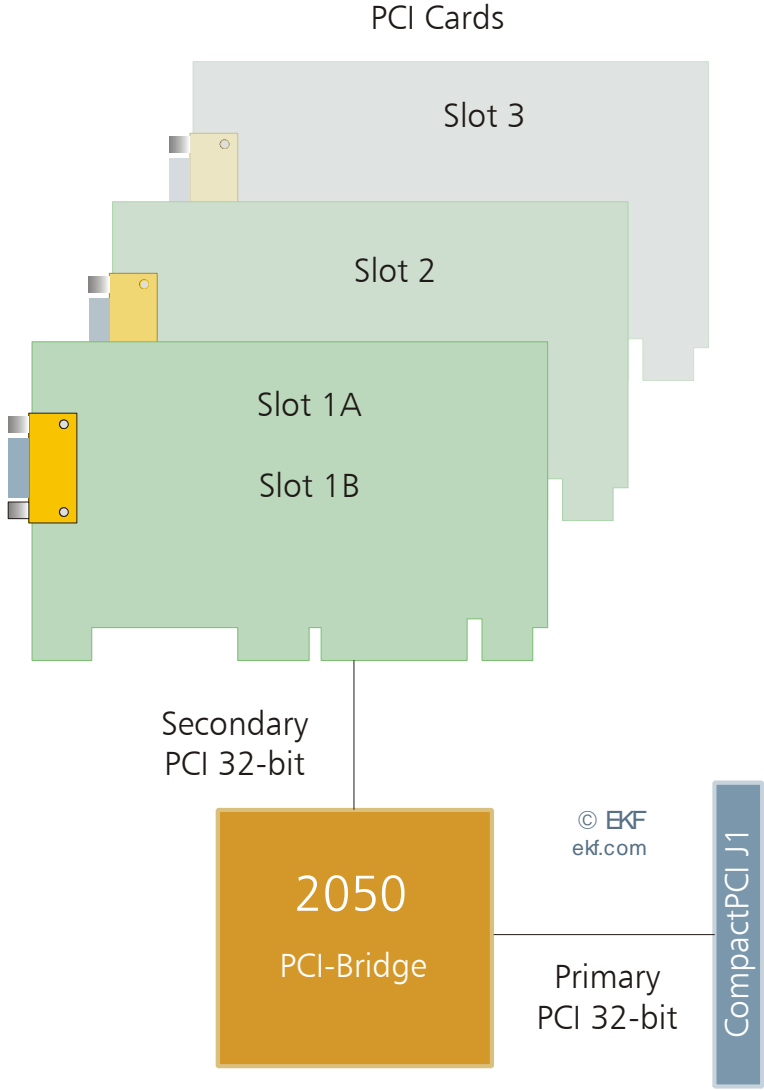

CA2-1-FUNK Top View

Mounting Instructions CA2-1-FUNK

(I) For proper mounting cut the PCI bracket as shown

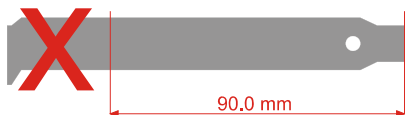

(II) Use block on the back side of the front panel (Detail A) to fasten the PCI board

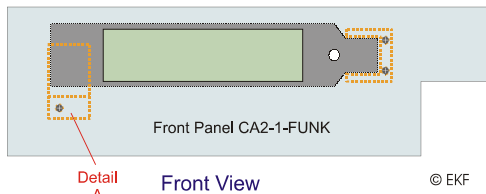

CA2-1-FUNK - fixing of the PCI bracket to the front panel (cutting of the PCI bracket required, observe max. dimensions of the PCI board)

Mounting Instructions CA2-2-FUNK:

- (I) Connect the pre-assembled fastener -1- to the boardpanel -2- with the screws -3-.
- (II) Use the screws -4- to fasten the pci boards. For normal use one screw is adequate.

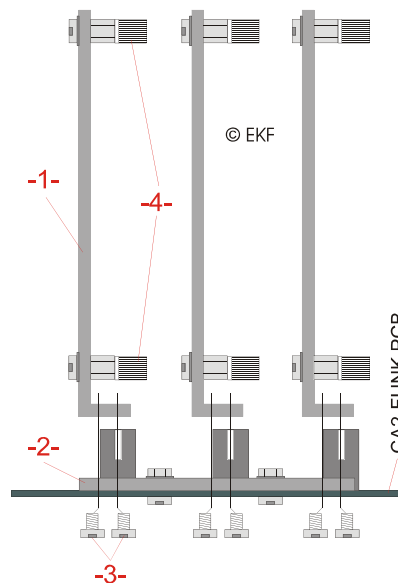

CA2-2-FUNK - fixing of the PCI boards to the holders (removing of the PCI brackets required)

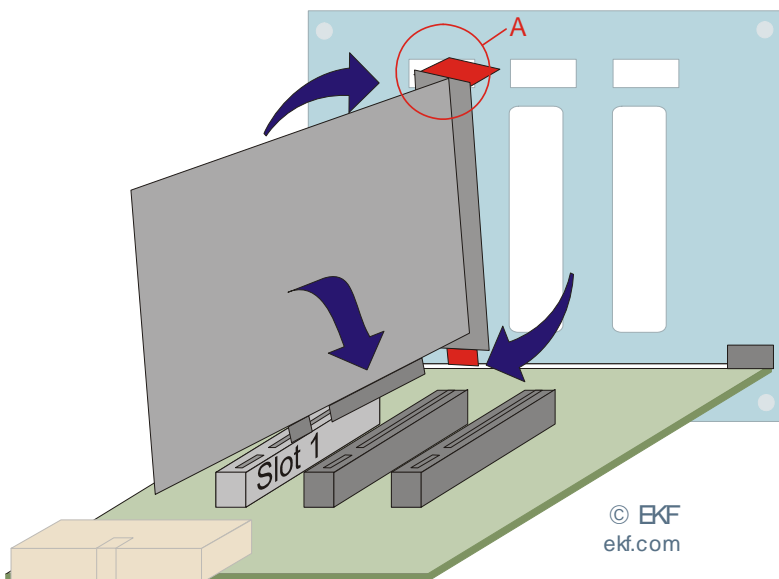

Mounting Instructions CA2-3-FUNK:

- Place the PCI board right along the chosen slot (e.g. Slot 1) and be sure that the top of the PCI bracket fits as shown in detail A
- Adjust the board over the slot and plug in. The bottom of the PCI bracket now fits in a holder for the slot.
- Proceed likewise for slot 2 and 3

## Technical Specifications

Printed Circuit Board Dimensions	<ul style="list-style-type: none"> <li>▶ 3U Eurocard (100x160mm<sup>2</sup>)</li> <li>▶ Front panel width 8HP (CA2-1)</li> <li>▶ Front panel width 4HP (CA2-2)</li> <li>▶ Front panel width 28HP (CA2-3, 4HP mounting space needed left to the CA2-3 slot, 24HP needed to the right side), or custom specific front panel</li> <li>▶ EMC shielding, ejection lever</li> </ul>
PCI Bus (internal) Local Slots 1a/1b 2 3	<ul style="list-style-type: none"> <li>▶ 32bit, 33MHz (133MBps), 5V interface,</li> <li>▶ Slot 1b (CA2-1) 90° right angle connector (horizontal mounting of a single PCI board with respect to the CA2-1 PCB), PCI Card max. 160x57mm<sup>2</sup></li> <li>▶ Slots 1a/2/3 (CA2-2 and CA2-3) 180° connectors (vertical mounting of up to three PCI boards with respect to the CA2-2/3 PCB), PCI Short Cards max. 160x106.68mm<sup>2</sup></li> </ul>
CPCI Bus (external)	32bit, 33MHz (133MBps), 3.3V or 5V Interface
Power Requirements	+5V ±5% (required for local PCI cards only) +3.3V ±0.3V 0.2A max. Vio (+5V or +3.3V) 0.1A max +12V ±5% (required for local PCI cards only) -12V ±5% (required for local PCI cards only) power consumption of local PCI boards not included
Temperature Humidity	<ul style="list-style-type: none"> <li>▶ Operating temperature 0-70 °C</li> <li>▶ Relative humidity 5-90%, non-condensing</li> </ul>

subject to change without further notice

Slot	IDSEL	REQ/GNT
1a/1b	AD31	0
2	AD30	1
3	AD29	2

Slot No. / IDSEL	Interrupt PCI Board	Interrupt J1 CompactPCI
1a/1b AD31	INTA# INTB# INTC# INTD#	INTD# INTA# INTB# INTC#
2 AD30	INTA# INTB# INTC# INTD#	INTC# INTD# INTA# INTB#
3 AD29	INTA# INTB# INTC# INTD#	INTB# INTC# INTD# INTA#

Ordering Information

For popular CA2-FUNK SKUs please refer to  
[www.ekf.com/liste/liste\\_20.html#CA2](http://www.ekf.com/liste/liste_20.html#CA2)



CA2-1-FUNK



CA2-1-FUNK

Industrial Computers Made in Germany  
boards. systems. solutions.

EKF Elektronik GmbH  
Philipp-Reis-Str. 4  
59065 Hamm  
Germany



Phone +49 (0)2381/6890-0  
Fax +49 (0)2381/6890-90  
Internet [www.ekf.com](http://www.ekf.com)  
E-Mail [info@ekf.com](mailto:info@ekf.com)