



User Guide

CG2-SHANTY • **CompactPCI**[®] GPS Receiver

Document No. 3775 • Edition 4

2006-03



Contents

About this Manual	3
Edition History	3
Nomenclature	3
Trade Marks	3
Legal Disclaimer - Liability Exclusion	3
CG2-SHANTY Features	4
Feature Summary	4
Short Description	5
Block Diagram	7
Top View Component Assembly	8
Front Panel	9
Front Panel Elements	10
Strapping Headers	10
Connectors & Sockets	10
Installation	11
Before You Begin	11
Warnings	11
Caution	11
Installing the Board	12
Jumper Configuration & Factory Defaults	13
Removing the Board	15
EMC Recommendations	16
Replacement of the Battery	17
Technical Reference	18
GPS Receiver Module	18
General Features	18
Serial Ports & Protocols	19
Auxiliary Power	19
Antenna Connector	20
Jupiter Module Socket	21
Jumper JUTC, Time Mark	22
Additional Documentation	23
Serial Interfaces	24
General Information	24
Connector SP2	25
CompactPCI® Interface	28
PCI Devices	28
System Connector J1	29
Literature	31

About this Manual

This manual describes some technical aspects of the CG2-SHANTY, required for installation and system integration. It is intended for the experienced user only.

Edition History

Ed.	Contents/Changes	Author	Date
1	User Manual CG2-SHANTY, english, initial edition (Text #3775, File: cg2_uge.wpd)	jb	15 September 2005
2	Added photo CG2-SHANTY Changed URL	jb	18 January 2006
3	Changed optional jumper setting	jb	2 March 2006
4	Added alternate photos CG2-SHANTY	jj	14 March 2006

Nomenclature

Signal names used herein with an attached '#' designate active low lines.

Trade Marks

Some terms used herein are property of their respective owners, e.g.

Pentium, Celeron, Socket 370: ® Intel
CompactPCI : ® PICMG
 Windows 98, Windows NT, Windows 2000: ® Microsoft

EKF does not claim this list to be complete.

Legal Disclaimer - Liability Exclusion

This manual has been edited as carefully as possible. We apologize for any potential mistake. Information provided herein is designated exclusively to the proficient user (system integrator, engineer). EKF can accept no responsibility for any potential damage caused by the use of this manual.

CG2-SHANTY Features

Feature Summary

Feature Summary	
Board Form Factor	3U Eurocard (100x160mm ²), front panel width 20.3mm (4HP)
Serial Interfaces SP1 (internally) SP2 (externally and internally) SP3, SP4 (optional usage)	<ul style="list-style-type: none"> ▶ Device: 16C550 compatible Quad PCI UART Oxford OXmPCI954 asynchronous serial protocol: 1 startbit; 7 or 8 databits; 1 or 2 stopbits; optional even/odd parity; bitrates up to 15Mbps ▶ SP1/SP2: typical settings for GPS operation SP1=4800Baud (GPS NMEA-0183), SP2=9600Baud (DGPS RTCM SC-104) ▶ SP2 front panel connector: PC compatible D-SUB connector 9-pin male, to be used either as DGPS input or as universal serial COM port, ESD protection 15kV, RS-232E transceiver can be disabled by removing jumper J-SP2 (option) ▶ SP3/SP4: on-board pin headers suitable for attachment of CU7-RS485 and CU8-RS232 PHY-modules (option) ▶ Serial driver software (COM port emulation) available
GPS Receiver	<ul style="list-style-type: none"> ▶ Exchangeable modular 12-channel receiver, chipset SiRFstarII, SMB jack for 1575,42MHz (L1 Band) GPS antenna, supply 0V (passive antenna), +5V, +3.3V (active antenna) selectable with jumper J-ANT ▶ Accuracy (horizontal) better than 3m (CEP), 5m (2 dRMS) ▶ Acquisition performance: hot start 8s, warm start 38s, cold start 45s ▶ Dead Reckoning capability ▶ SRAM and RTC data non-volatile buffered by Lithium cell 190mAh (> 10000h) ▶ Selected NMEA-0183 ASCII messages: latitude, longitude, elevation, velocity, heading, time, satellite tracking status, command/control messages (primary serial I/F) ▶ SiRF binary protocol: raw data (primary serial I/F) ▶ RTCM ASCII protocol (secondary serial I/F) ▶ 1pps output with better than 1us timing accuracy
CompactPCI® Bus	<ul style="list-style-type: none"> ▶ 32-bit 33MHz (133MB/s) ▶ +5V/+3.3V V_{IO} (J1 connector not keyed)
Power Consumption	<ul style="list-style-type: none"> ▶ +5V ±0.25V 0.1A max. ▶ +3.3V ±0.15V 0.15A max.
Environmental Conditions	<ul style="list-style-type: none"> ▶ Operating temperature: -40°C ... +85°C ▶ Storage temperature: -40°C ... +85°C ▶ Humidity 5% ... 95% non-condensing ▶ Altitude -300m ... +18000m ▶ Shock 15g 0.33ms, 6g 6ms ▶ Vibration 1g 5-2000Hz
MTBF	tbd h

specifications are subject to change without further notice

Short Description

Whenever the global time (UTC) or the geographic position is needed in a **CompactPCI®** based application, the GPS receiver board **CG2-SHANTY** is a perfect choice.

Often industrial computer systems need synchronization to a precise time standard. A solution to this problem would be any radio controlled clock. Unfortunately, most regions have their own local transmitter standards. Hence, for universal use (e.g. if systems are mobile or destined for export), a GPS based clock is preferable.

The CG2-SHANTY 3U Eurocard is provided with a high performance receiver engine continuously tracking all satellites in view for a time accuracy better than 1 μ s and horizontal accuracy better than 3m. The receiver is compatible with passive or active antennas and supports the NMEA-0183 data protocol, thus allowing nearly any GPS application program to be used with it.

The CG2-SHANTY module lends full GPS functionality to any **CompactPCI®** system. If GPS technology can solve your problem, this board is the perfect and affordable choice.

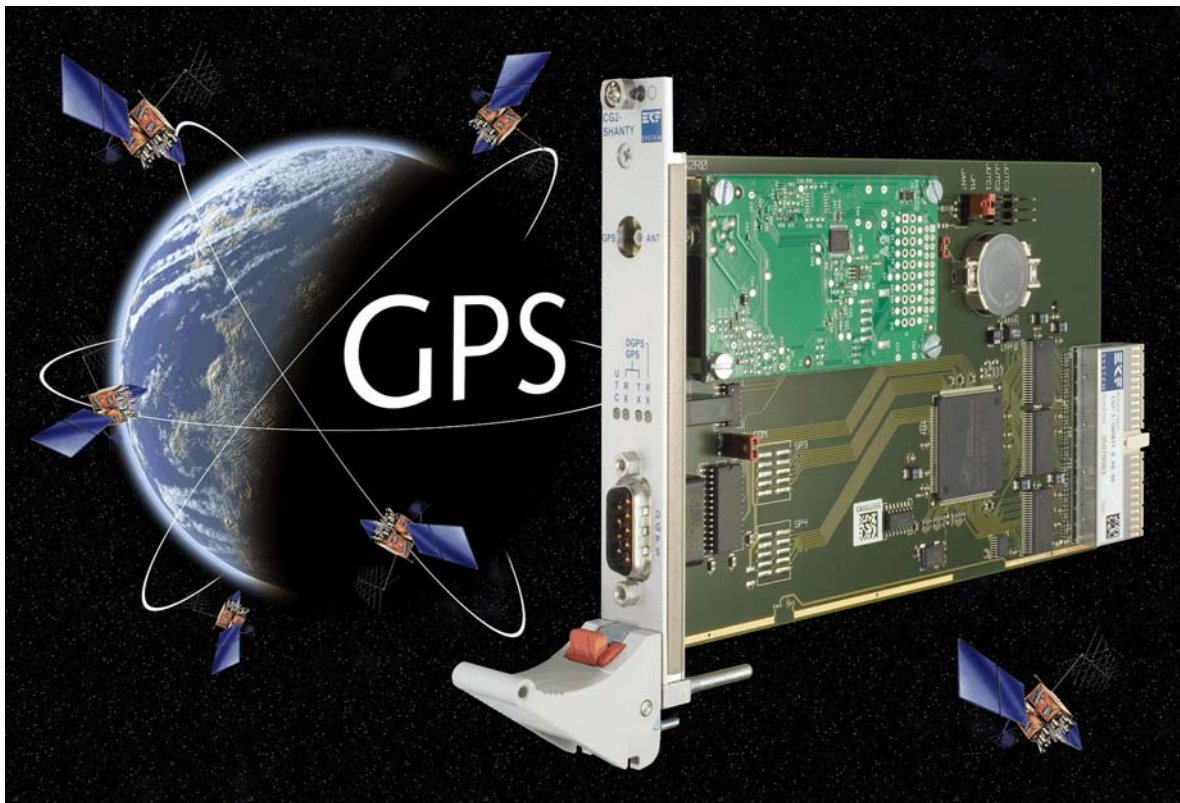

The CG2-SHANTY incorporates a highly integrated digital GPS receiver, which uses the SiRFstarII chipset and is accommodated on a miniature daughter board as an exchangeable mezzanine sub-assembly. The 12-channel architecture provides rapid Time-To-First-Fix (TTFF) under all startup conditions. The receiver decodes and processes signals from all visible GPS satellites, thereby producing a highly accurate and robust navigation solution. In a typical situation, a horizontal accuracy better than 3m can be achieved. The external GPS antenna connects to the front panel mounted SMB style jack and must have reasonable visibility of the sky. For best performance, use an active antenna (+5V or +3.3V selectable power), in particular for a cable length of 3m and beyond.

Under certain conditions, differential RTCM SC-104 data capability can further enhance the positioning accuracy. For that, the CG2-SHANTY is equipped with an additional serial port for communication with an external DGPS (Differential GPS) receiver.

With respect to the CompactPCI bus, the CG2-SHANTY appears as a quad serial adapter card, based on 16C550 compatible PCI UARTs (which are also known as COM-ports in a typical PC). The first serial port of the CG2-SHANTY is for on-board use only. It serves as the communications interface to the GPS receiver. Commands and data can be sent to and received from the GPS daughter board according to the NMEA-0183 standard protocol. When operated in NMEA ASCII mode, the moderate transmission rate of 4800bps cares for low interrupt load of the system host. As an option, the SiRF binary raw data protocol allows much higher throughput.

The second serial port is intended either as external DGPS interface (read only), or as a general purpose RS-232E communications channel. The wiring of the front panel mounted 9-pin male D-SUB connector is identical to desktop PC COM ports. When receiving differential DGPS data at 9600bps according to the RTCM SC-104 standard, the GPS daughter module uses this information for its internal calculations to sharpen the positioning data. The second serial interface is also directly readable by the system host. Programs as LabMon can process DGPS data in parallel to the GPS receiver data for presentation.

The remaining two serial ports are currently not in use. However, the CG2-SHANTY can be optionally equipped with connectors suitable for attachment of external PHY transceiver modules (EKF CU-series, e.g. CU7-RS485).

The CG2-SHANTY provides a pulse output (1pps) with better than 1us timing accuracy, which can be used to generate interrupts in order to synchronize processes.

Available by download, the EKF utility WinGPS displays the GPS data and allows to synchronize the system clock with the UTC (Universal Time Coordinated). In addition, the Internet is full of GPS shareware tools. The common basis of most applications is the NMEA-0183 protocol, so that they should be usable with the CG2-SHANTY without any modification. Furthermore, there are various commercial GPS application programs available, mostly allowing comfortable cartographical visualization.

Block Diagram

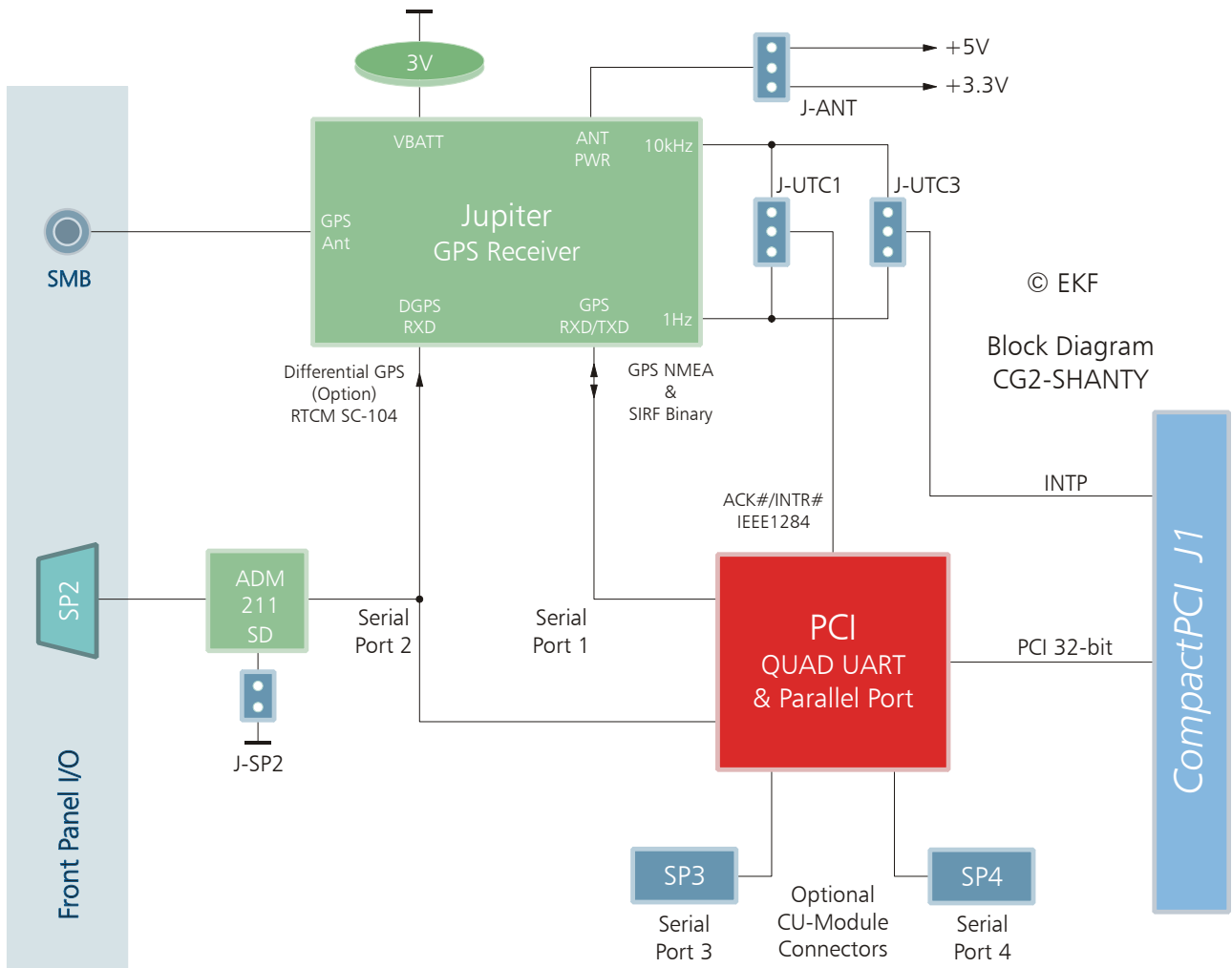

Top View Component Assembly

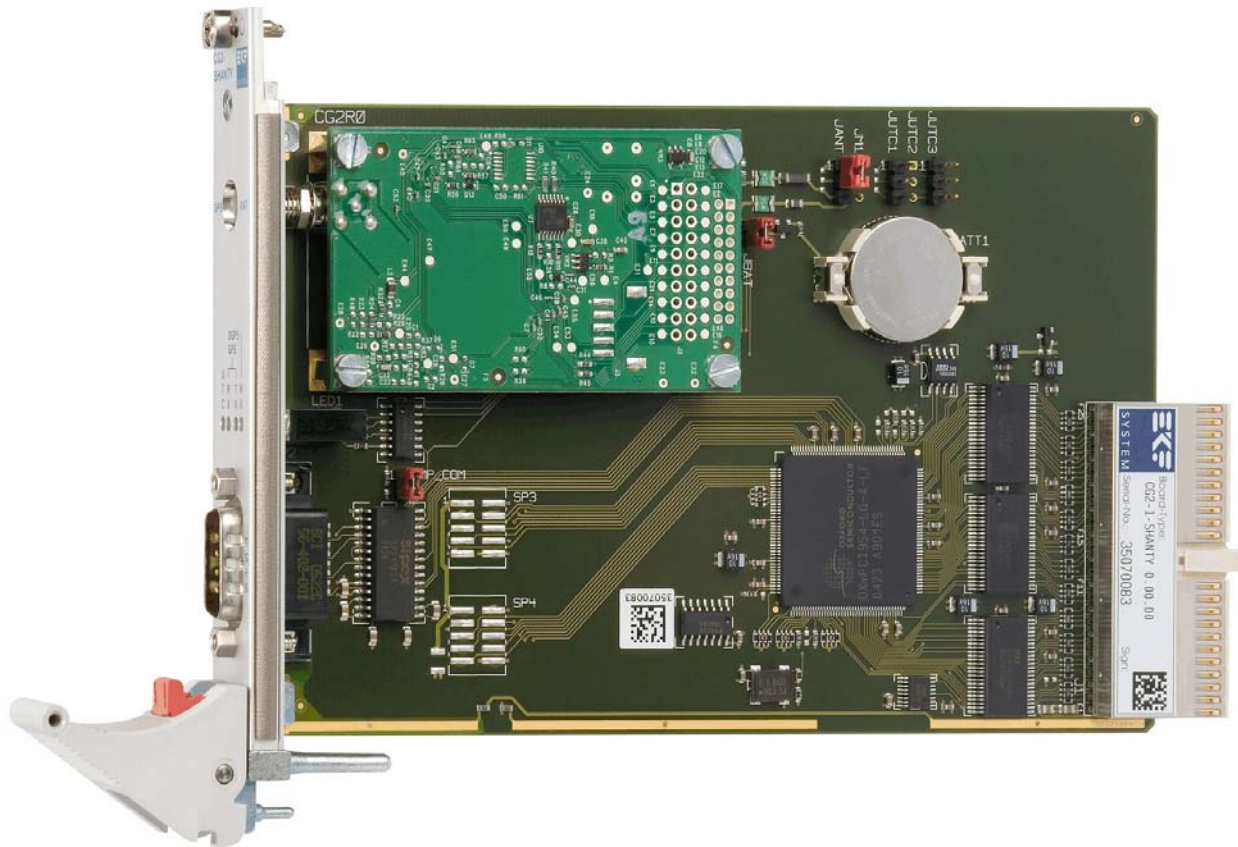
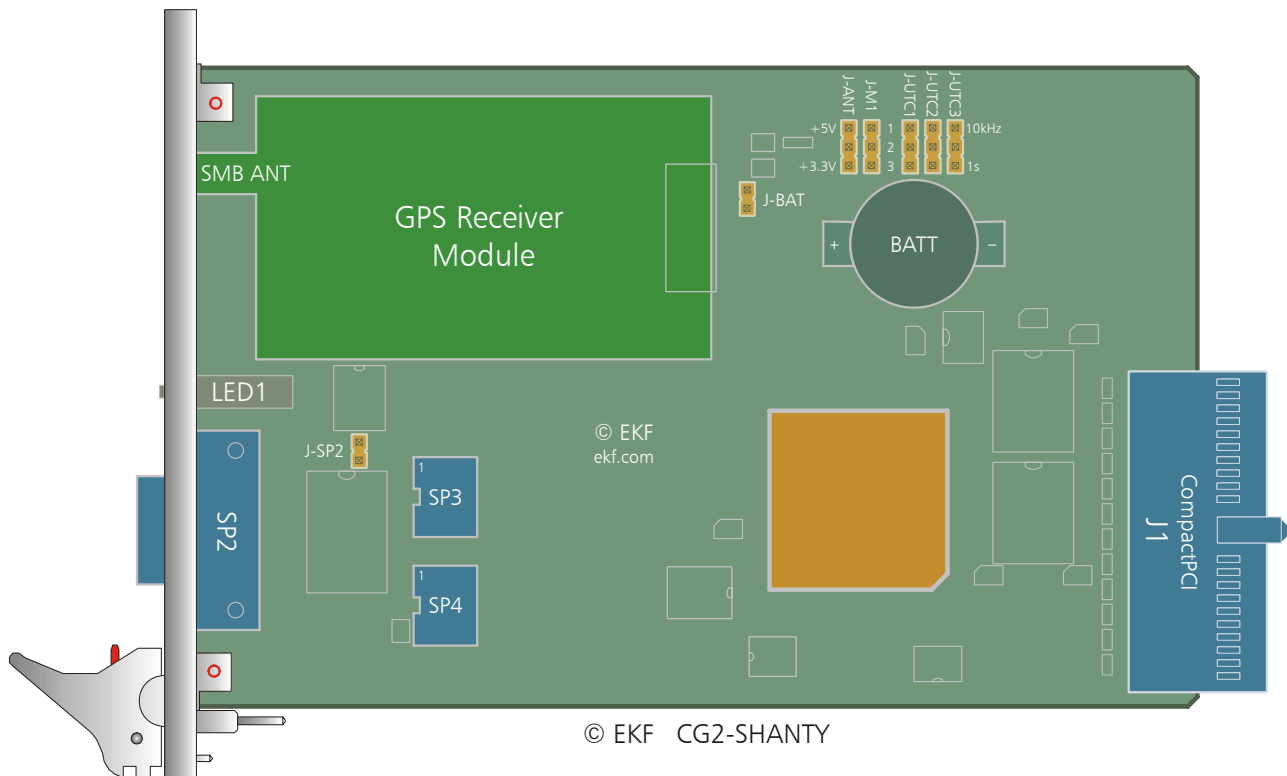

Front Panel

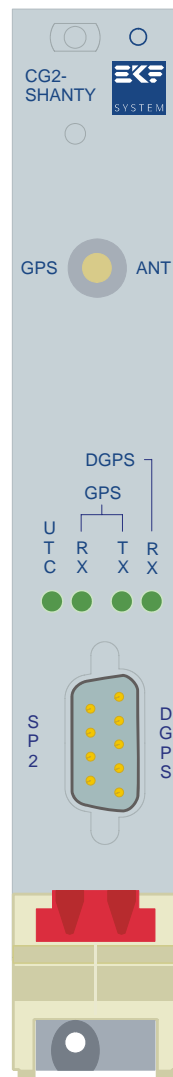

Front Panel Elements

ANT	RF input 1575,42MHz (L1 band), GPS antenna active or passive, input signal level at -130dBW ... -163dBW, SMB jack, power supply voltages selectable 0V, +5V, +3.3V (jumper JANT), PolySwitch resettable fuse 0.5A
SP2	RS-232E D-SUB 9 male connector, can be used either as universal serial COM-port (standard bitrates up to max. 115,2 kBaud), or as DGPS input (according to RTCM SC-104 protocol, 9600bps, 8bit, 1 startbit, 1 stopbit, no parity)
LED Array	UTC pulse 1s period RXD/TXD GPS receiver module RXD serial port SP2

Strapping Headers

JANT	Antenna passive, antenna active +5V, antenna active +3.3V
JBAT	Lithium battery for data retention of GPS module's RTC and SRAM
JUTC1	TTL time mark pulse 1Hz or 10kHz connected to PCI QUAD UART (Optional)
JUTC3	TTL time mark pulse 1Hz or 10kHz for synchronisation connected to INTP (J1 D4) (Optional)
JMP_COM	Transceiver for SP2 Enabled/Disabled (Optional)

Connectors & Sockets

JUTC2	TTL time mark pulse 1Hz and 10kHz, synchronized to the UTC Universal Time (Coordinated) (Optional)
-------	--

Installation

Before You Begin

Warnings

The procedures in this chapter assume familiarity with the general terminology associated with industrial electronics and with safety practices and regulatory compliance required for using and modifying electronic equipment. Disconnect the system from its power source and from any telecommunication links, networks or modems before performing any of the procedures described in this chapter. Failure to disconnect power, or telecommunication links before you open the system or perform any procedures can result in personal injury or equipment damage. Some parts of the system can continue to operate even though the power switch is in its off state.



Caution

Electrostatic discharge (ESD) can damage components. Perform the procedures described in this chapter only at an ESD workstation. If such a station is not available, you can provide some ESD protection by wearing an antistatic wrist strap and attaching it to a metal part of the system chassis or board front panel. Store the board only in its original ESD protected packaging. Retain the original packaging (antistatic bag and antistatic box) in case of returning the board to EKF for repair.



Installing the Board

Warning

This procedure should be done only by qualified technical personnel. Disconnect the system from its power source before doing the procedures described here. Failure to disconnect power, or telecommunication links before you open the system or perform any procedures can result in personal injury or equipment damage.

Typically you will perform the following steps:

- Switch off the system, remove the AC power cord
- Attach your antistatic wrist strap to a metallic part of the system 
- Remove the board packaging, be sure to touch the board only at the front panel
- Configure any jumpers on the board according to your application (see next page 'Jumper Configuration')
- Identify the related CompactPCI slot (peripheral slot for I/O boards)
- Insert card carefully (be sure not to damage components mounted on the bottom side of the board by scratching neighbored front panels)
- A card with on board connectors requires attachment of associated cabling now
- Lock the ejector lever, fix screws at the front panel (top/bottom)
- Retain original packaging in case of return

Jumper Configuration & Factory Defaults

Before inserting the CG2-SHANTY into your CPCI enclosure, please control the settings of some jumper fields on the board. Typically, there are two jumpers that need adjustment.

- Set the jumper JBAT. This enables the Lithium cell, which provides for saving satellite tracking information in a buffered SRAM, and supplies the RTC, which is operating as clock source while the system is powered down or there is no receiver signal available on the antenna input.
- Check the jumper JANT according to the antenna in use. If your antenna is equipped with a cable more than 2m length, probably it has a built-in amplifier (active antenna). If you cannot determine the type of antenna, try the passive mode first (JANT open). Observe the front panel LED UTC, which sends a periodic signal when the receiver gets valid GPS data (there may be some delay time). If this procedure is not successful, set the JANT jumper to the +5V active antenna mode. Note: GPS antennas need free sky above them (mounting outside the building required).

JBAT

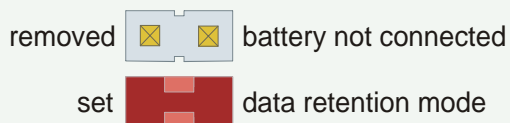

JBAT provides for non-volatile GPS RTC & SRAM data (Lithium cell)

jumper removed - saves cell lifetime while board storage (delivery status)

jumper set - data retention mode
factory default is off - check this setting if TTF is slow

you have to set this jumper on a new board - EKF opens this jumper for storing and shipping

JANT

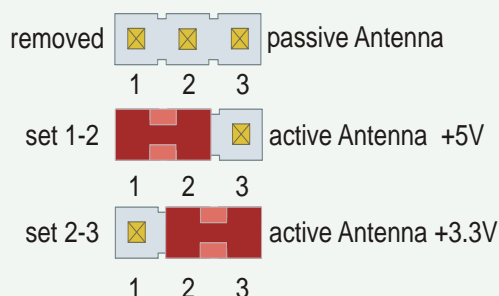

**WARNING: unmatched JANT settings may destroy antenna
check setting anytime before connecting GPS antenna**

Check your antenna type in use! If in doubt, remove jumper (passive antenna).

If your active antenna needs a +5V power supply set 1-2

If your active antenna needs a +3.3V power supply set 2-3

- The CG2-SHANTY can be used to synchronize external events with the UTC (Universal Time Coordinated). Two single row 3-pin headers (JUTC1 & JUTC3) are provided optional to route the time signal to the UART controller or directly to the INTP pin on the CompactPCI backplane (J1 D4).

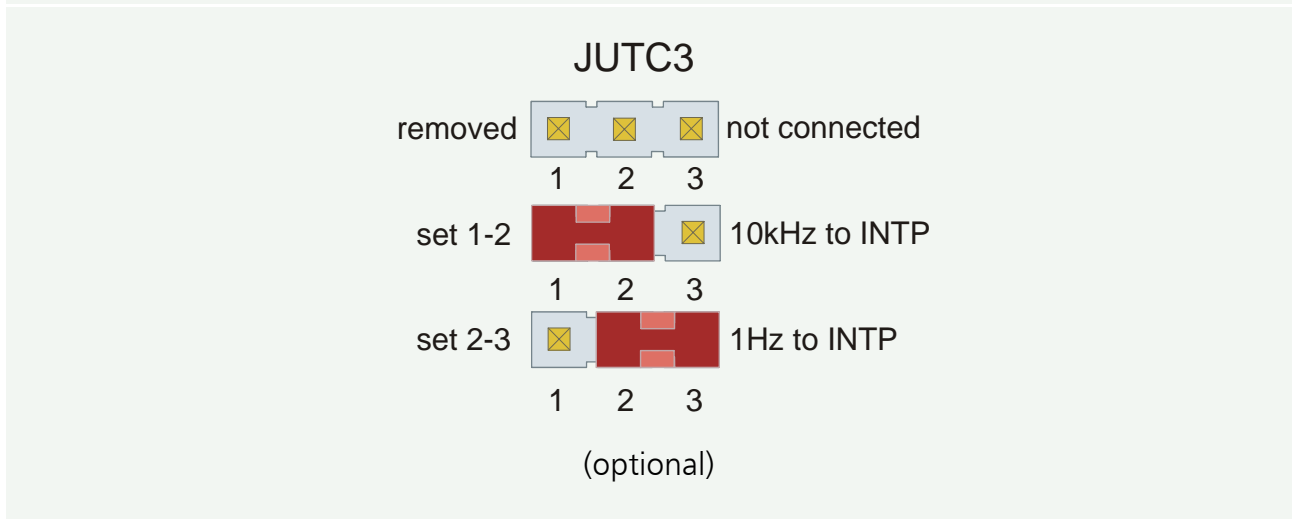
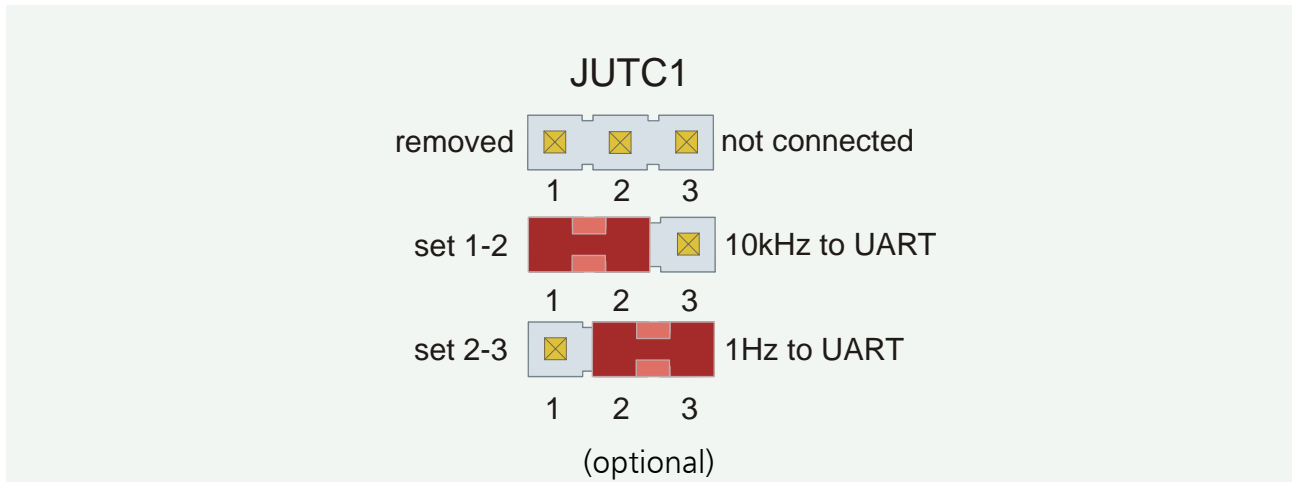

- Optional, one single row 2-pin header (JMP_COM) is provided to enable/disable the onboard RS232 transceiver.

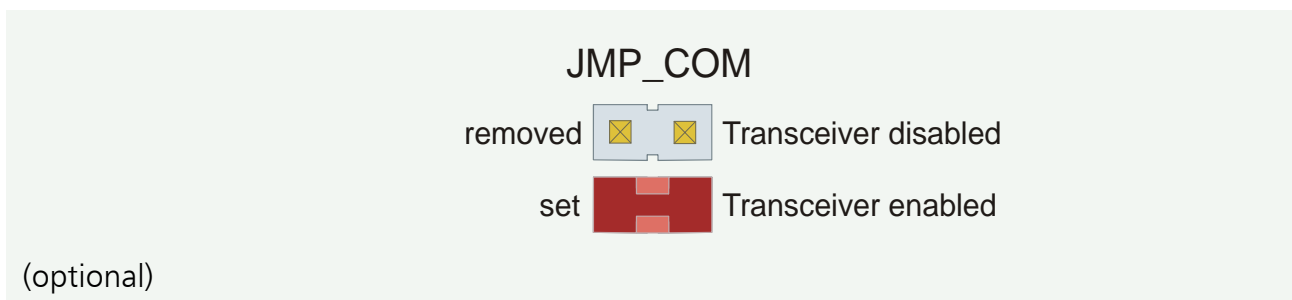

Removing the Board

Warning

This procedure should be done only by qualified technical personnel. Disconnect the system from its power source before doing the procedures described here. Failure to disconnect power, or telecommunication links before you open the system or perform any procedures can result in personal injury or equipment damage.

Typically you will perform the following steps:

- Switch off the system, remove the AC power cord
- Attach your antistatic wrist strap to a metallic part of the system 
- Identify the board, be sure to touch the board only at the front panel
- unfasten both front panel screws (top/bottom), unlock the ejector lever
- Remove any onboard cabling assembly
- Activate the ejector lever
- Remove the card carefully (be sure not to damage components mounted on the bottom side of the board by scratching neighboured front panels)
- Store board in the original packaging, do not touch any components, hold the board at the front panel only

Warning

Do not expose the card to fire. Battery cells and other components could explode and cause personal injury.



EMC Recommendations



In order to comply with the CE regulations for EMC, it is mandatory to observe the following rules:

- The chassis or rack including other boards in use must comply entirely with CE
- Close all board slots not in use with a blind front panel
- Front panels must be fastened by built-in screws
- Cover any unused front panel mounted connector with a shielding cap
- External communications cable assemblies must be shielded (shield connected only at one end of the cable)
- Use ferrite beads for cabling wherever appropriate
- Some connectors may require additional isolating parts

Reccomended Accessories

Blind CPCI Front Panels	EKF Elektronik	Widths currently available (1HP=5.08mm): with handle 4HP/8HP without handle 2HP/4HP/8HP/10HP/12HP
Ferrit Bead Filters	ARP Datacom, 63115 Dietzenbach	Ordering No. 102 820 (cable diameter 6.5mm) 102 821 (cable diameter 10.0mm) 102 822 (cable diameter 13.0mm)
Isolating Elements	ARP Datacom, 63115 Dietzenbach	Ordering No. 182 068 (Cheapernet T-connector)
Metal Shielding Caps	Conec-Polytronic, 59557 Lippstadt	Ordering No. CDFA 09 165 X 13129 X (DB9) CDSFA 15 165 X 12979 X (DB15) CDSFA 25 165 X 12989 X (DB25)

Replacement of the Battery

When your system is turned off, a battery maintains the current time-of-day clock and the values in the GPS receiver modules CMOS RAM current. The battery allows for nominal 4750hrs data retention. For replacement, the old battery must be removed from its socket. Change it against the same type only (Panasonic CR2032 3V). Observe the cell polarization - the '+' mark appears on top.

Be very careful when removing the battery from its socket. Do not damage any components or copper traces situated under the battery holder.

Warning

Danger of explosion if the battery is incorrectly replaced. Replace only with the same or equivalent type. Do not expose a battery to fire.



Technical Reference

GPS Receiver Module

General Features

The CG2-SHANTY is equipped with the Navman Jupiter GPS receiver module, a 12 parallel channel receiver engine. Each of these receivers continuously tracks all satellites in view and provides accurate satellite positioning data. The Jupiter module size is about 28 square centimeters and satisfies harsh industrial requirements. The Jupiter module decodes and processes signals from all visible GPS satellites. These satellites, in various orbits around the Earth, broadcast radio frequency (RF) ranging codes and navigation data messages. The Jupiter receiver uses all available signals to produce a highly accurate and robust navigation solution.

The 12-channel architecture provides rapid Time-To-First-Fix (TTFF) under all startup conditions. While the best TTFF performance is achieved when time of day and current position estimates are provided to the receiver, the flexible SiRF signal acquisition system takes advantage of all available information to provide a rapid TTFF. Acquisition is guaranteed under all initialization conditions as long as visible satellites are not obscured. To minimize TTFF following a power down, the Jupiter receiver is sourced by a Lithium Cell on the CG2-SHANTY board to maintain power to the Static Random-Access Memory (SRAM) and Real-Time Clock (RTC) for periods following the loss of prime power. The use of the battery voltage assures the shortest possible TTFF following a short power down. The Jupiter receiver supports two dimensional (2-D) operation when less than four satellites are available or when required by operating conditions. Altitude information required for 2-D operation is determined by the receiver.

The Jupiter module contains two independent serial ports, one of which is configured for primary input and output data flow using the National Marine Electronics Association (NMEA-0183) format. The second port is used to receive Differential GPS (DGPS) corrections in the Radio Technical Commission For Maritime Services (RTCM SC-104) format. The Jupiter receiver supports DGPS operations for dramatically improved accuracies over standard GPS (while Selective Availability is activated by US government). The primary I/O port of the Jupiter (NMEA) is connected to the first port of the UART controller, while the secondary port (RTCM) is connected to both the front panel connector SP2 and the second port of the UART controller of the CG2-SHANTY (see block diagram CG2-SHANTY).

For applications that require timing synchronization to GPS accuracies, the Jupiter receiver provides an output timing pulse that is synchronized to one second Universal Time Coordinated (UTC) boundaries. This timing pulse is available by an two single row headers JUTC1 and JUTC3 on the CG2-SHANTY board. This timing signal could generate a timing interrupt on the UART controller therefore JUTC1 should be set. Its also possible to use this timing signal to generate a timing interrupt directly on the INTP of the CompactPCI bus (J1 d4). The CompactPCI CPU boards CC9-SAMBA and CD2-BEBOP are already capable of handling this interrupt. This timing pulse is also used to drive an indicator LED visible from the CG2-SHANTY boards front panel.

Serial Ports & Protocols

The Jupiter module communicates with the host across its primary serial port. The bit rate is fixed to 4800bps, no parity, 8 data bits, 1 stop bit. Commands are passed to the module, which responds accordingly with results and status information. Due to the low data transfer rates, there is no hardwired handshake available.

There are two choices for protocol selection. By default, the NMEA standard is selected on the Jupiter Module. This is an ASCII based protocol, widely accepted as a common base to all GPS application programs. As an alternate, the Jupiter module can be configured to communicate by a proprietary, binary protocol (SiRF binary messages). On writing own firmware, the binary protocol could be a more efficient solution. The binary protocol also allows for defining higher bit rates on both serial interfaces. Please contact EKF when you need the binary protocol feature.

The secondary (auxiliary) serial port of the Jupiter module is configured as a half duplex input at 9600bps, no parity, 8 data bits, one stop bit. This interface is configured to receive RTCM DGPS correction data messages. Usage of this port is optional.

There are four indicator LEDs mounted in the front panel to signal both RXD and TXD of the primary serial interface, and RXD only of the auxiliary serial interface.

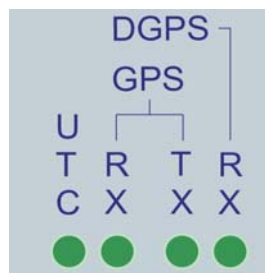

Auxiliary Power

The CG2-SHANTY is equipped with a Lithium cell battery. Close the jumper JBAT to provide this auxiliary power to the Jupiter receiver module (you have to set this jumper for any new board, because the factory default is off for saving cell lifetime while storing). Data retention for the GPS receivers SRAM and RTC is nominal 4750hrs. Loss of SRAM or RTC data results in slower response time (TTFF) after powering up the CG2-SHANTY, but the GPS receiver remains fully operable. For replacement of the battery, observe precautions and follow the procedure described in chapter 'Replacement of the Battery'.

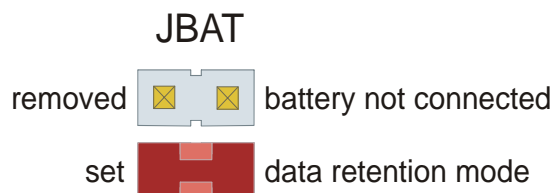

Antenna Connector

The Jupiter receiver is equipped with a SMB type miniature coaxial female connector as RF signal input from the antenna. The antenna cable therefore should provide a matching SMB plug. When ordering an antenna, be sure to have selected the SMB connector version, if the antenna cable is directly attached (there are several other common connector types on the market, e.g. SMA, TNC and OSX). If the antenna is equipped with a built-in connector, an additional adapter cable is required, matching both, the antenna type of connector at the outer end, and a SMB male connector on the CG2-SHANTY side. The SMB connector should be a straight type, not right angle style. A right angle connector might have a profile too low to allow full insertion into the matching jack on the CG2-SHANTY, which is mounted behind the front panel, due to EMC requirements.

For best results, use an active GPS antenna with built-in amplifier, especially when the cable length exceeds 2m. Typical gain is 10...50db; a longer cable needs higher gain to compensate its loss. Active antennas are powered by +3.3V or +5V across the coaxial cable, selected by the jumper field JANT. Do not obscure the antenna (mounting outside of the building required).

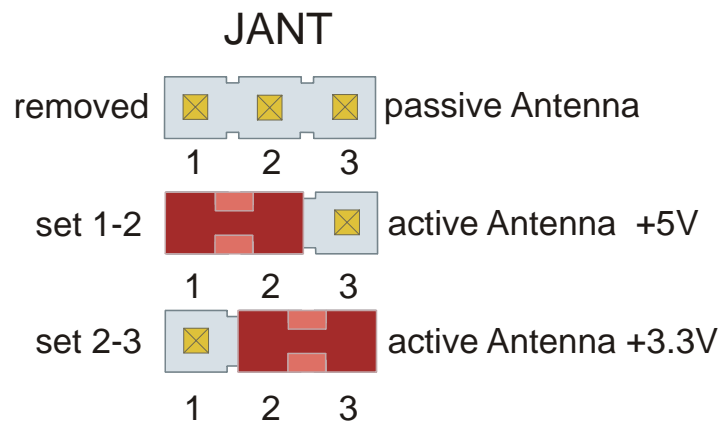

**WARNING: unmatched JANT settings may destroy antenna
check setting anytime before connecting GPS antenna**



Heavy Duty Airborne GPS Antenna

Jupiter Module Socket

The Jupiter receiver module fits into a dual row, 20-position, 2.0mm metric socket and is mechanically fixed by 4 screws .

Socket1			
+3.3V ¹	1	2	+3.3V/+5V Antenna ²
+3.3V ¹	3	4	VBATT
GYRO ⁵	5	6	RESET#
GPIO3 ⁴	7	8	GPIO2 ⁴
GND	9	10	SPEED ⁵
Serial Data In 1	11	12	Serial Data Out 1
NC	13	14	GND
GND	15	16	Serial Data In 2 ³
GND	17	18	GND
UTC 10kHz	19	20	UTC TMARK

¹ Jupiter receiver power, fused by PolySwitch 0.5A

² Antenna power, from JANT, selectable NC/+3.3V/+5V, fused by PolySwitch 0.5A

³ RTCM DGPS optional input, can be fully deactivated by removing R12 and placing R11

⁴ GPIO2/3 inputs are used to setup some Jupiter options, see table below

⁵ Connector pin function only in combination with Jupiter 21D (optional)

GPIO2	Resistor Stuffed	Jupiter Option
0	R10 stuffed	NMEA 4800bps ASCII protocol, no parity, 1 start bit, 8 data bits, 1 stop bit, default

GPIO3	Resistor Stuffed	Jupiter Option
0	R8 stuffed R7 removed	Jupiter receiver gets its initializing parameters from its ROM
1	R7 stuffed R8 removed	Jupiter tries to read initializing parameters from its SRAM first (if valid), else from its EEPROM (if valid), else falls back to its ROM stored parameters, default

Jumper JUTC, Time Mark

The CG2-SHANTY can be used to synchronize external events with the UTC (Universal Time Coordinated). The board generates two output signals, named **utctmark** and **utc10kHz**, which can be used for various purposes. Both signals are wired to the (optional) 3-pin header connector JUTC.

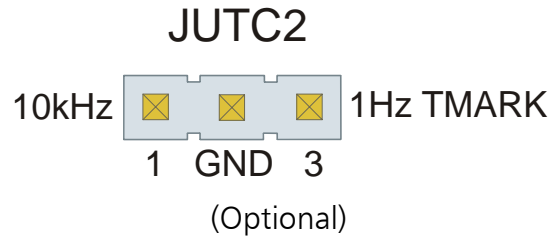

This connector is located near the Lithium cell. If the board is not equipped with this (optional) connector, the position can easily be filled by the customer with a three pin 0.1" (2.54mm) pitch header.

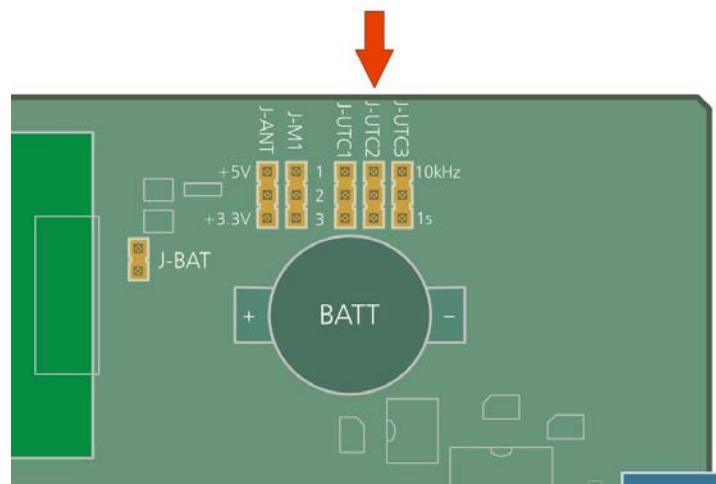

The Time Mark output **utctmark** provides a one pulse-per-second (1pps) signal to the user specific application. When the receiver provides a valid navigation solution, the rising edge of each utctmark pulse is synchronized with the UTC one second epochs to within $\pm 300\text{ns}$. This signal is a positive logic, buffered CMOS level output pulse that transitions from a logic 'low' condition to a logic 'high' at a 1 Hz rate. The pulse duration is typically 25.6ms. The 10kHz UTC Synchronized Clock signal **utc10kHz** is a symmetric, buffered CMOS level output, synchronized to the utctmark pulse.

Additional Documentation

In addition to this manual, EKF provides detailed on-line information regarding the Jupiter receiver module (PDF documents). Also use the Navman homepage for most recent information:

<http://www.navman.com>

Document Title	URL http://
Jupiter 21 GPS Receiver Data Sheet	www.ekf.com/c/cgps/cg2/inf/jupiter21_datasheet.pdf
NMEA Reference Manual	www.ekf.com/c/cgps/cg2/inf/nmea_reference_manual.pdf
SiRF Binary Protocol Reference Manual	www.ekf.com/c/cgps/cg2/inf/binary_reference_manual.pdf
pointers to some other documentation	www.ekf.com/c/cgps/cg2/cg2_e.html

The NMEA and RTCM protocol specifications can be obtained from

<http://www.nmea.org/>

<http://www.rtc.org/>

Connector SP2

The illustration below shows the pin assignment of the connector SP2 (front view to the connector). Signal directions are seen from the view of the CG2-SHANTY, e.g. RXD (SP2, pin 2) is an input to the CG2-SHANTY.

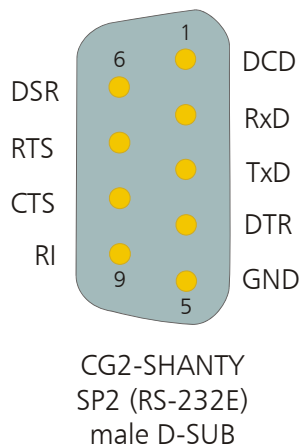

Male D-Sub 9 Connector (PC compatible)

SP2 (RS-232E)		
	1	DCD
DSR	6	
	2	RXD
RTS	7	
	3	TXD
CTS	8	
	4	DTR
RI	9	
	5	GND

The signal RXD (typically data from external DGPS receiver) can be observed from an indicator LED mounted in the front panel of the CG2-SHANTY.

The following figure shows the wiring scheme of a standard RS-232 link cable usually in use to connect a port of the CG2-SHANTY with another RS-232 port, e.g. a COM port of a PC:

Link Cable RS-232 for interconnection between CG2-SHANTY serial port (SP2) and PC COM port

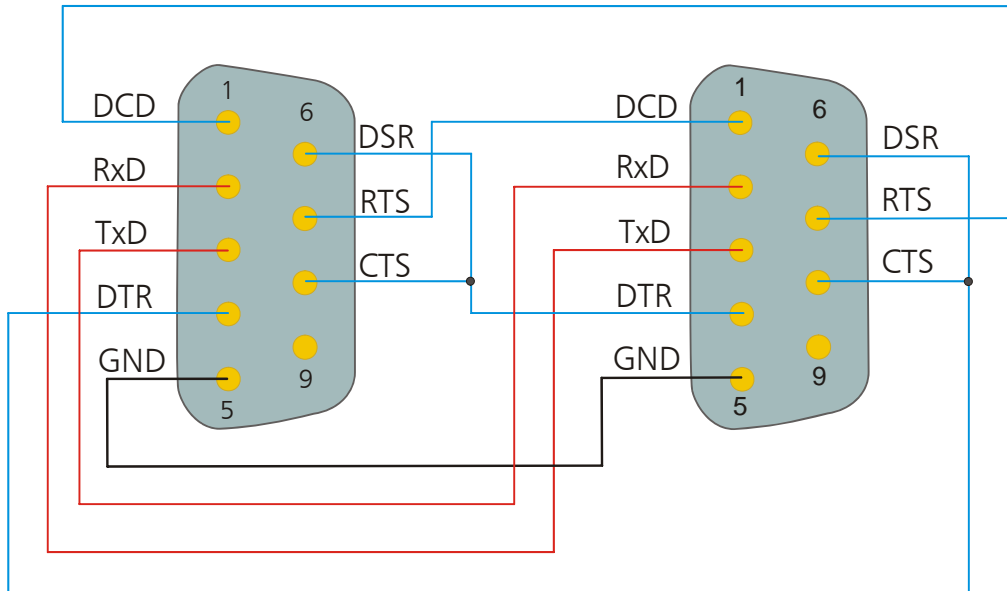

connectors: shielded female D-SUB 9
complete cable assembly available
EKF part no. 280.7.201

To establish a connection between the serial port SP2 and the external DGPS receiver, a three wire cable should be used as shown in the diagram below:

Connection Cable RS-232
for interconnection between
CG2 serial port (SP2) and
WZ WFE97 DGPS Receiver

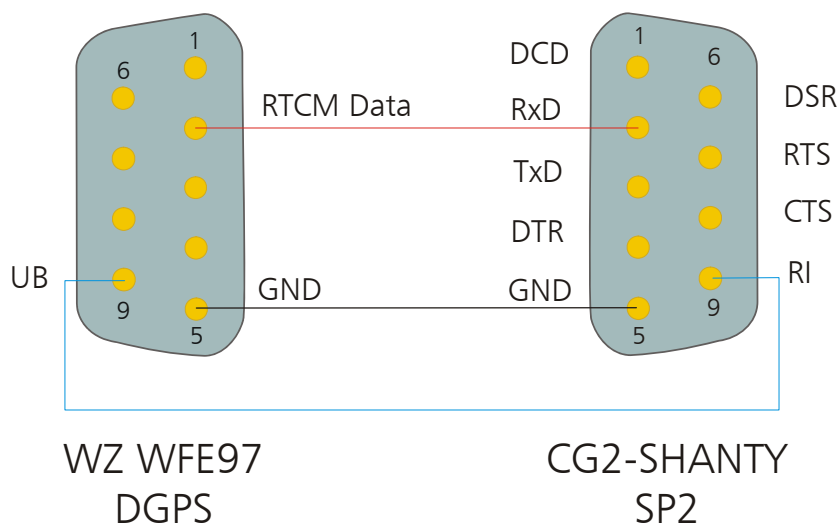

connectors shielded D-SUB 9
CG2-SHANTY: female connector
WZ WFE97 DGPS: male connector
cable is included with DGPS receiver

CompactPCI® Interface

The CG2-SHANTY offers a *CompactPCI*® interface complying to the *CompactPCI*® Specification Revision 2.1. *CompactPCI*® is an industrial implementation of the familiar *Peripheral Component Interconnect* (PCI) bus. It combines the well known electrical features of PCI with the more robust mechanical 19 inch rack mounting technology. The interface supports 64-bit address and 32-bit data transfers. It is designed for a clock frequency of 33 MHz with a transfer rate of up to 132 Mbyte/s.

PCI Devices

The *CompactPCI*® interface is realized by the UART Controller (Oxford OXmPCI954). This controller has four UARTs (Universal Asynchronous Receiver Transmitter). Two ports are internally used, the other two ports could be used for custom specific solutions. Normally a BIOS running on a host system detects these PCI devices at boot time.

System Connector J1

The *CompactPCI*[®] specification defines the usage of shielded, 2 mm-pitch, 5-row connectors on *CompactPCI*[®] boards according to IEC 917 and IEC 1076-4-101. The 32-bit PCI interface is implemented via the J1 connector, while the 64-bit option requires the connector J2. Since the CG2-SHANTY has a 32-bit *CompactPCI*[®] interface, the J2 connector is not necessary and thus not mounted.

The J1 connector also defines the supported signaling voltage (V_{IO}). A coding key in this connector is used to distinguish boards with $V_{IO}=3.3V$ (cadmium yellow key), $V_{IO}=5V$ (brilliant blue key) or both (no key). The CG2-SHANTY is suitable for $V_{IO}=3.3V$ and $V_{IO}=5V$ and therefore not equipped with any coding key.

CompactPCI J1

#J1	A	B	C	D	E
25	+5V	REQ64#	<i>ENUM#</i>	+3.3V	+5V
24	AD1	+5V	VI/O	AD0	ACK64#
23	+3.3V	AD4	AD3	+5V	AD2
22	AD7	GND	+3.3V	AD6	AD5
21	+3.3V	AD9	AD8	M66EN	C/BE0#
20	AD12	GND	VI/O	AD11	AD10
19	+3.3V	AD15	AD14	GND	AD13
18	SERR#	GND	+3.3V	PAR	C/BE1#
17	+3.3V	<i>IPMB SCL</i>	<i>IPMB SDA</i>	GND	PERR#
16	DEVSEL#	GND	VI/O	STOP#	LOCK#
15	+3.3V	FRAME#	IRDY#	<i>BD_SEL#</i>	TRDY#
14					
13			Not Keyed		
12					
11	AD18	AD17	AD16	GND	C/BE2#
10	AD21	GND	+3.3V	AD20	AD19
9	C/BE3#	IDSEL	AD23	GND	AD22
8	AD26	GND	VI/O	AD25	AD24
7	AD30	AD29	AD28	GND	AD27
6	REQ#	GND	+3.3V	CLK	AD31
5	<i>BRSVP1A5</i>	<i>BRSVP1B5</i>	RST#	GND	GNT#
4	<i>IPMB PWR</i>	GND	VI/O	INTP	<i>INTS</i>
3	INTA#	INTB#	<i>INTC#</i>	+5V	<i>INTD#</i>
2	<i>TCK</i>	+5V	<i>TMS</i>	TDO ¹	TDI ¹
1	+5V ²	-12V ²	<i>TRST#</i>	+12V ²	+5V

Pin positions printed italic/gray: Not connected

¹ TDI/TDO internally connected together

² +5V/+12V/-12V not required

Literature

Theme	Document Title	Origin
<i>CompactPCI</i> Specification	<i>CompactPCI</i> Specification, PICMG 2.0 R3.0, Oct. 1, 1999	PICMG (http://www.picmg.org)
PCI	PCI Hardware and Software Architecture & Design, Solari/Willse, 4th Edition, Annabooks	Annabooks (http://www.annabooks.com)
Metric Connectors	IEC 1076-4-101 Application Literature from ERNI, AMP, FCI	Beuth Verlag, Berlin ILI Index House, GB SL57EU Ascot Berkshire
2.54mm Shrouded Headers	DIN 41651	Beuth Verlag, Berlin



EKF Elektronik GmbH
Philipp-Reis-Str. 4
59065 HAMM
Germany



Fax. +49 (0)2381/6890-90
Tel. +49 (0)2381/6890-0
Internet www.ekf.com
E-Mail info@ekf.de